

TECHNICAL DATASHEET

PEFS C6 / F3 / F3N Cylinder Brackets

Features

The Chubb PEFS C6 / F3 / F3N cylinder bracket features:

- Australian Standard compliant to AS5062
- Meets AS5062 vibration and shock test requirements.
- Mild steel construction
- Polyester powder coated black
- Available in 4 sizes to fit PEFS cylinders
- Optional mounting weld lugs available



PEFS C6
Vehicle Fire Suppression System

PEFS F3
Vehicle Fire Suppression System

PEFS F3N
Vehicle Fire Suppression System

Chubb Fire & Security Pty Ltd
13 15 98
www.chubb.com.au

ABN 47 000 067 541

Chubb

Specifications



128735 – C23 Cylinder Bracket

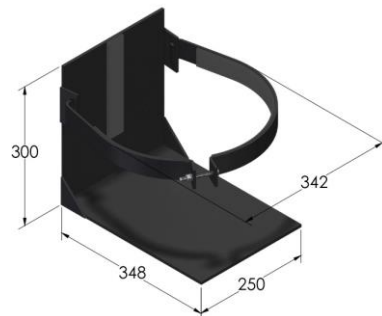

128736 – C30 Cylinder Bracket

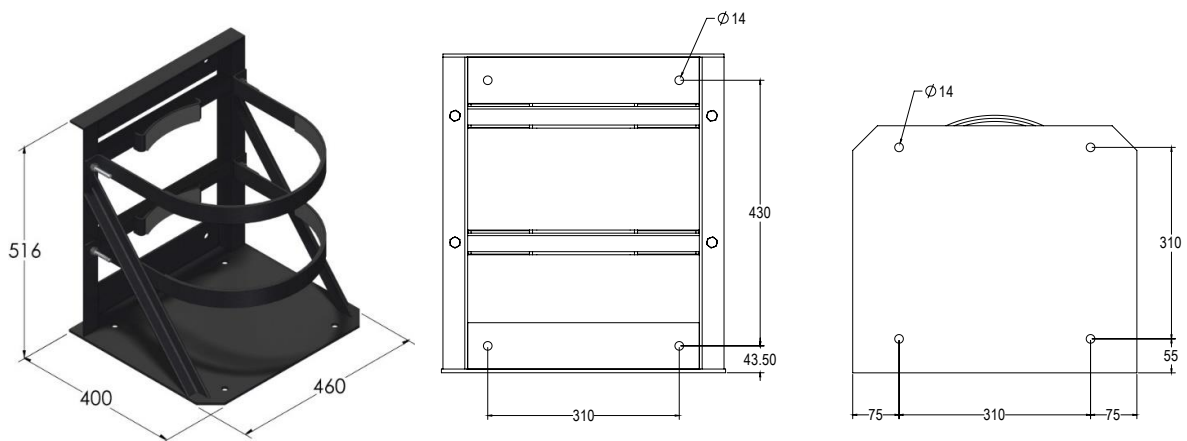

128737 – C45 & C65 Cylinder Bracket

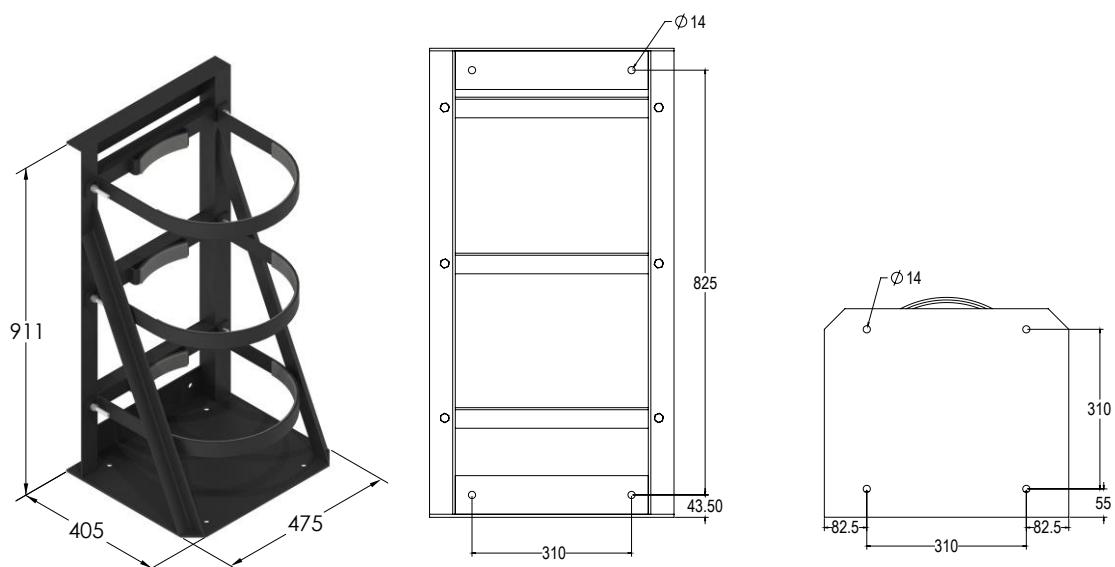

128738 – C106 Cylinder Bracket